

Talent

by Alegre Design

Talent was created to consolidate a single solution that met all the arising needs in spaces that aim to motivate critical thinking, innovation and the transfer of knowledge in a much more active, fun and creative way.

The program is structured around two areas: The Talent Series 500 for office training areas and the Talent Series 300 and 100 for multiuse spaces. For office and operational positions, the Talent Series 500 has high-standing tables with an aluminium base, on castors with adjustable height and even a large model with a height of up to 138cm.

Technical data

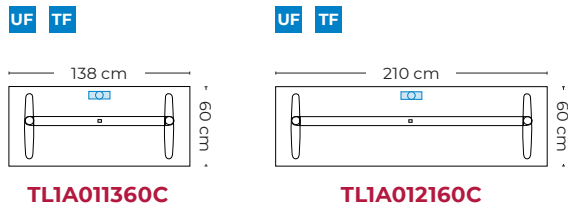
Table program	3
Talent Series 100 · Features, functionalities & Accessories	4
Talent Series 300 · Features, functionalities & Accessories	5
Joining system · Talent Series 100 & 300	6
Talent Series 500 · Features, functionalities & Accessories	7
Finishes available	8
Access to wiring & connections	9
Packs, weights & volumes	10
Ecodesign	10
Regulations & EPD	10
Certificates	10



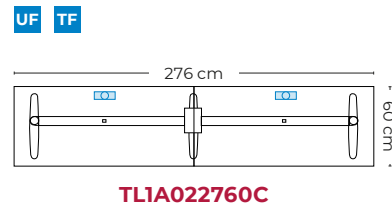
Table program

Talent 100 · Fixed desks with levelers

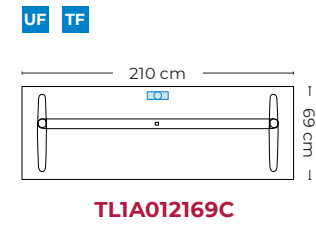
Straight desks · Width 60 cm



Straight progressive tables · Width 60 cm

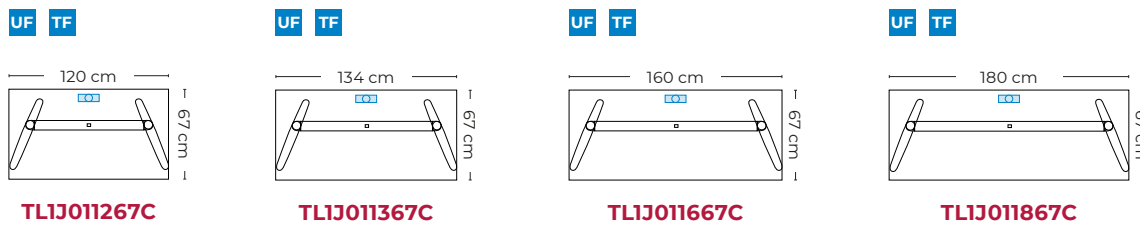


Straight desks · Width 69 cm

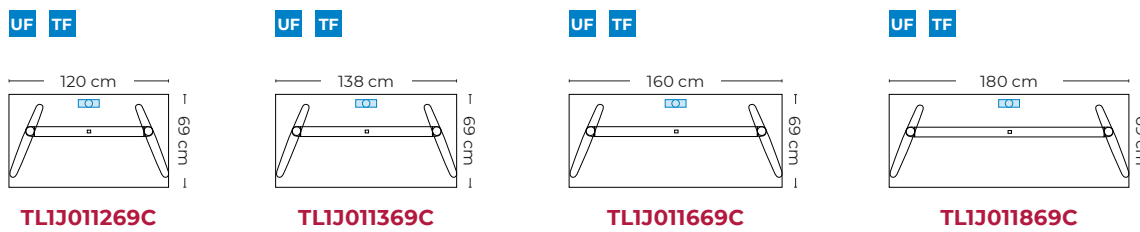


Talent 300 · Fixed desks with castors and folding desk-top

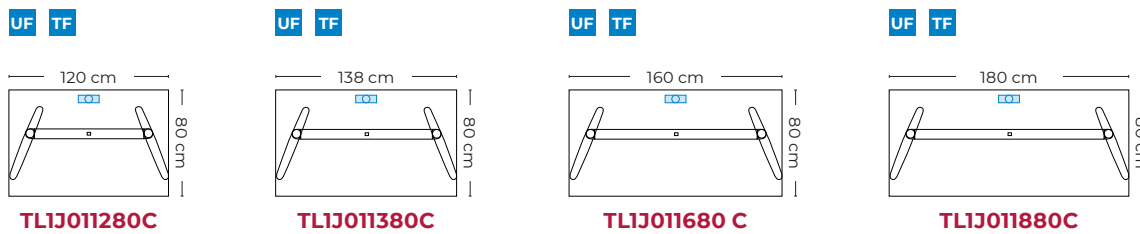
Straight desks · Width 67 cm



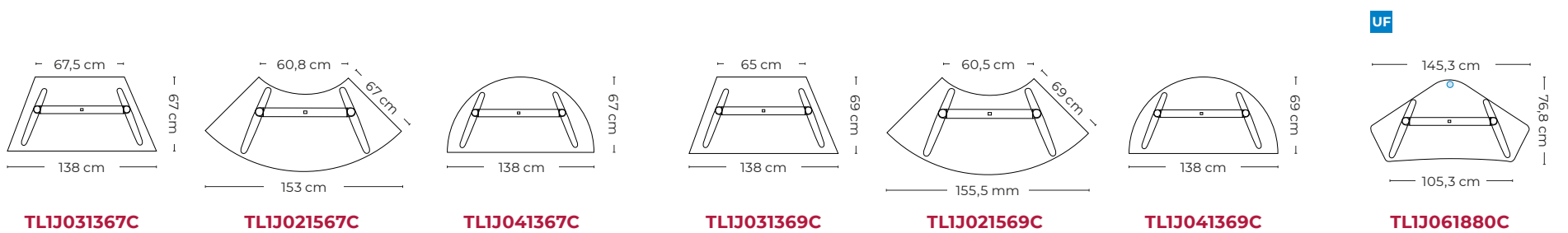
Straight desks · Width 69 cm



Straight desks · Width 80 cm

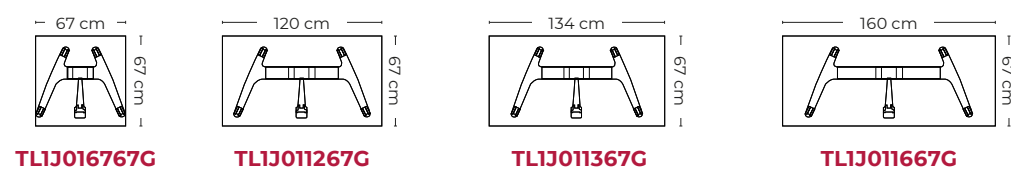


Collectivity desks · Width 67, 69 y 80 cm

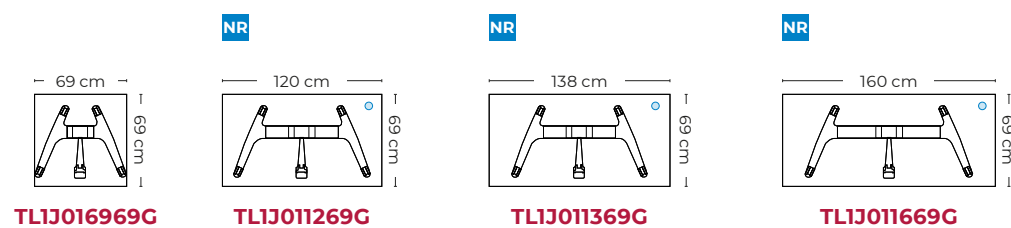


Talent 500 · Lift-up tables with castors & folding desk-top

Straight desks · Width 67 cm



Straight desks · Width 69 cm



Talent Series 100 · Features, functionalities and add-ons



- 1** 25 mm Melamine surface with PVC straight edge.
- 2** Bracket in 3mm folded steel sheet in white and black finish with an epoxy paint coating.
- 3** 70x40 and e=2 mm steel tube recessed beam with stop for safety support of the deck.
- 4** Extruded aluminum column Ø60 mm in white and black finish with an epoxy paint coating.
- 5** Straight injection-molded aluminum feet in white and black finish coated with epoxy paint.
- 6** Ø46mm levelers with non-skid patch.

Accessories

Cable management



Ø80mm "U" wiring access.



Push Latch "T" wiring access.



Metallic tray for access to "T" wiring.

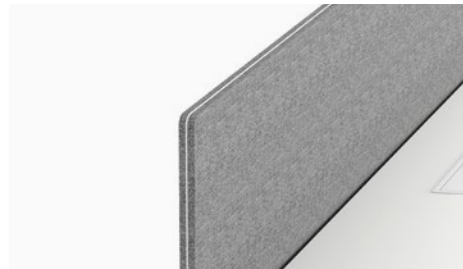


Individual high-capacity metal cable tray.



Flexible polypropylene cable riser.

Desk top screens



Talent offers a variety of options in partitions. Fully upholstered, with aluminum profiles or guides for fixing 3rd level elements, melamine, glass or methacrylate.

Modesty panel



Melamine or veneer skirt.

CPU support



Metal bracket anchored to the beam

Linking of desks



Anchoring by means of plastic clamp e=4mm

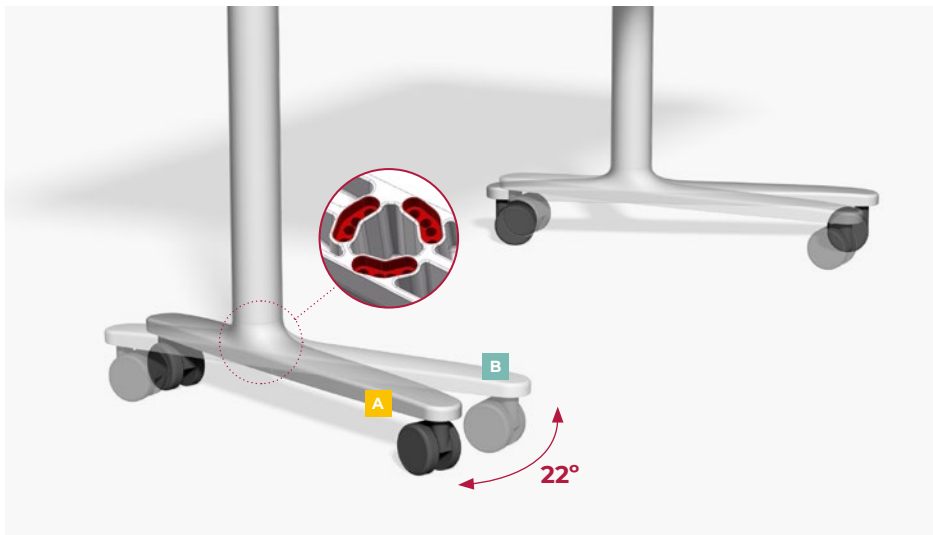
Talent Series 300 · Features, functionalities and add-ons



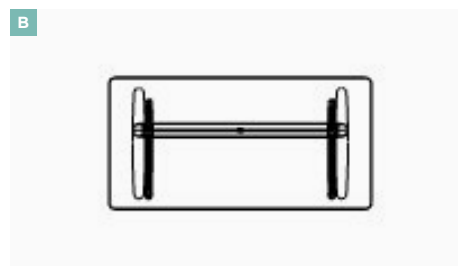
- 1** 25 mm melamine surface with PVC edge and rubber cushioning.
- 2** Folding desk top with locking/unlocking system.
- 3** Aluminum injection bracket in white and black finish with an epoxy paint coating.
- 4** Elbow for joining columns and beams in die-cast aluminum.
- 5** Polypropylene protective trim.
- 6** 73x70 and e=2 mm extruded aluminum recessed beam, with stop for safety support of the deck.
- 7** Extruded aluminum column Ø60 mm in white and black epoxy coated finish.
- 8** Aluminum injection molded feet in white and black finish coated with epoxy paint.
- 9** Stacking protection on feet.
- 10** Black castors of 65 mm diameter. 2 with brake and 2 without brake.

Placement of feet in angular position

The 300 series is offered as standard with a 22° inclined foot. This series offers the possibility to change the feet to a straight foot version by unscrewing the foot and placing the screws in the indicated position.



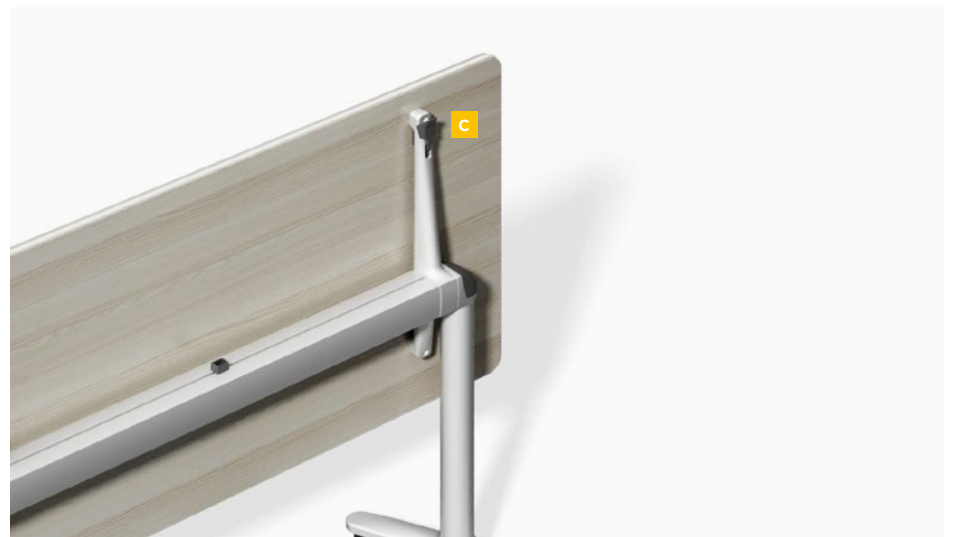
Foot placement at 22 degrees



Placement of the feet in an upright position

Board surface tiltability

The 300 series offers a folding system of the work surface, by means of a system in the brackets, with unlocking and locking position of the mechanism. At the same time, this folding system allows the tables to be stacked in a space-saving manner. The tables are equipped with a stacking protector at the feet.



Locking/unlocking system of the work surface folding in 2 positions.



Hinged skirt anchored to melamine-finished board.

Accessories

Cable management



Ø80mm "U" wiring access.



Push Latch "T" wiring access.



Metallic tray with access to "T" wiring.



Flexible polypropylene cable riser.

Folding modesty panel



Melamine skirt

Linking of desks



Quick linking. The desks are prepared to be linked laterally and frontally. They are fixed using a e=4mm plastic bracket

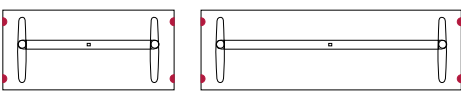
Jointing system · Talent Series 100 & 300

Talent, in its 100 and 300 series, allows a fast system of Linking of desks, so that different configurations can be made, achieving that the tables have stability and there are no undesired movements in their use. The tables are prepared to be joined laterally and frontally, by means of a plastic clamp of e= 4mm, which has a fast and simple system of union.

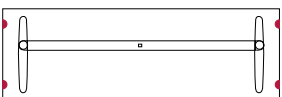


Table models with connecting systems

Talent Series 100 · Fixed desks with levelers · Side connection

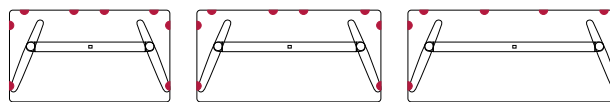


60 cm wide Straight desks

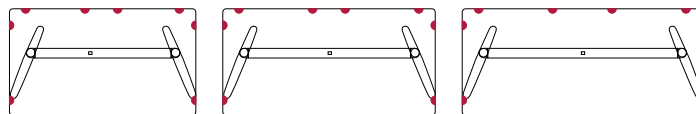


69 cm wide Straight desks

Talent Series 300 · Fixed desks with castors and hinged top · Side and front connection

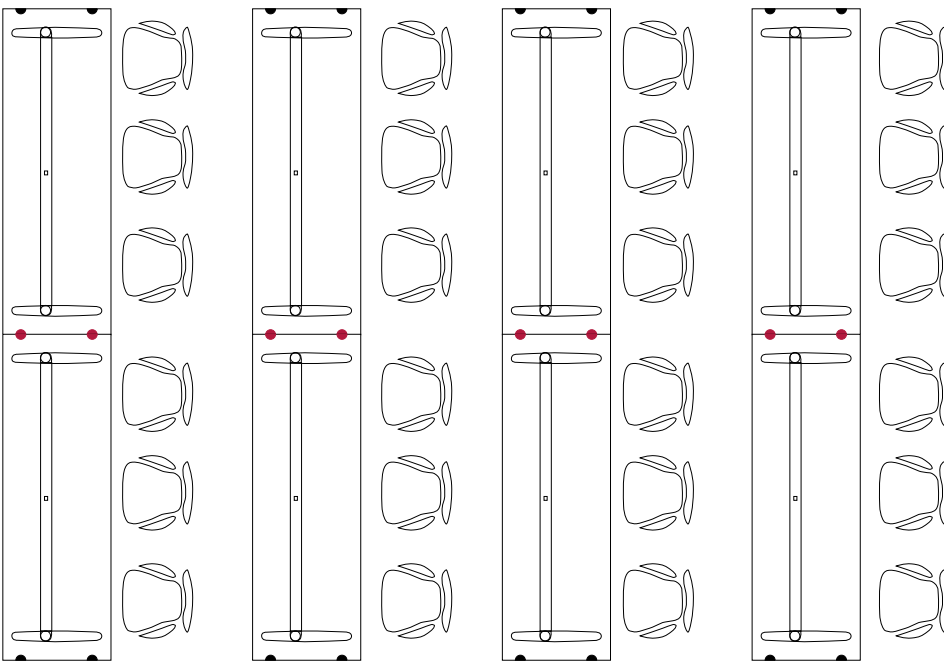


67 and 69 cm wide Straight desks

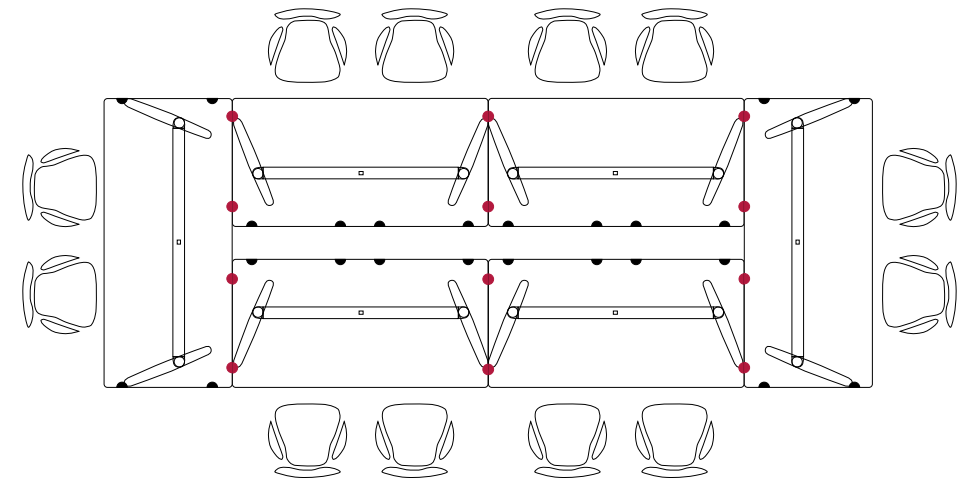


80 cm wide Straight desks

Configuration examples



Lateral joints



Side and front connections

Talent Series 500 · Features, functionalities and add-ons



- 1 25 mm melamine surface with PVC edge and rubber cushioning.
- 2 Folding desk top with locking/unlocking system.
- 3 Aluminum injection bracket in white and black finish with an epoxy paint coating.
- 4 Elbow for joining columns and beams in die-cast aluminum.
- 5 Polypropylene protective trim.
- 6 Table lifting system by means of a compensated gas pump.
- 7 73x70 and e=2 mm extruded aluminum recessed beam, with stop for safety support of the deck.
- 8 Telescopic central column in extruded aluminum with two sections of 110x80 and 100x70 mm and e=2 mm, with elevation by gas cylinder, in white and black finish with an epoxy paint coating.
- 9 Feet with lateral connection, made of aluminum injection in white and black finish coated with epoxy paint.
- 10 Stacking protection on feet.
- 11 Black castors of 65 mm diameter. 2 with brake and 2 without brake.

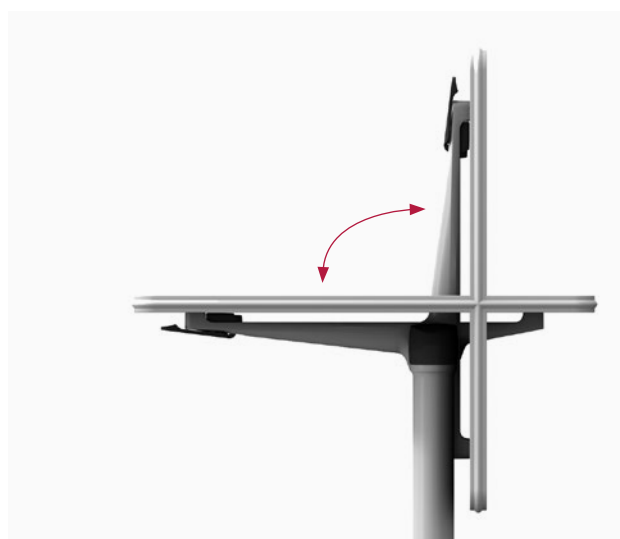
Lifting system

The 500 series has a push button under the table top, easily accessible, which allows the table to be raised by means of a gas pump. Height range: 74-104 cm.



Folding the desk top desk-top

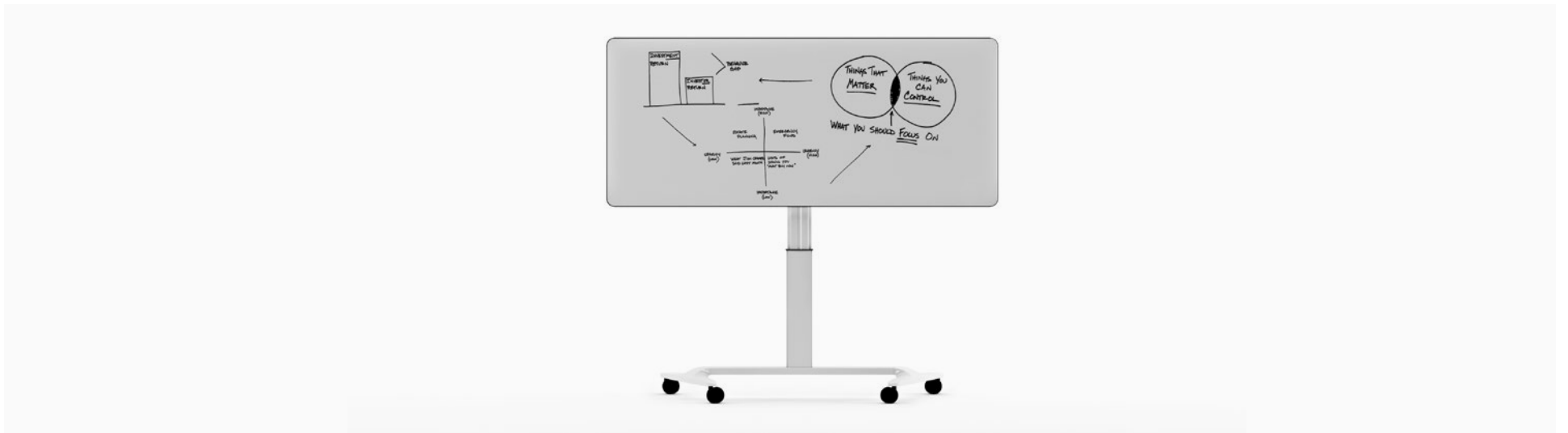
The 500 series offers a folding system of the work surface, by means of a system in the brackets, with unlocking and locking position of the mechanism. At the same time, this folding system allows the tables to be stacked in a space-saving manner. The tables are equipped with a stacking protector at the feet.



Locking/unlocking system of the work surface folding in 2 positions.

Laminated writing surface

24 mm laminated surface with PVC edge and shock-absorbing rubber. Melamine surface laminated in white. For correct writing and long-lasting durability of the table surface, the use of dry-erase markers is recommended. Easy and clean erasure with a simple cloth or eraser, even when the writing has been done for some time. The use of chemical products for cleaning the surface is not recommended.



Talent Desks with connectivity without detracting from mobility



- 1** All models, as standard, incorporate an integrated connection access in the table surface, with a round, flat, minimalist-looking plug integrated into the table. 1 x Schucko + 2 USB charger. Dimensions: Ø10,8 x h:15,3cm.
- 2** Hook made of 3 mm thick steel plate, anchored to the bracket with the capacity to collect the wiring in a simple and clean way.
- 3** Metallic wiring riser, made of 0.8 mm thick steel plate anchored to the column without reducing mobility (elevation), which allows easy cable routing, providing visual cleanliness.
- 4** Built-in 3m long cable wrapped in a textile wiring harness, with zipper system, with additional protection against flame and abrasion.

8



Finishes available

Surface





Structure



Access to cabling and connections

How to order tables with overhead wiring access

WIRING ACCESS U	WIRING ACCESS T
	
<p>Polypropylene cover with a diameter of 80 mm for the passage of wiring to the lower part. The upper part incorporates a small flange for the passage of small wiring and allows the complete cover to be removed for the passage of a large amount of wiring.</p> <ul style="list-style-type: none"> - To request a table with higher access to wiring must be added: <ul style="list-style-type: none"> · Access wiring U: the letter U at the end of the requested reference. - The models that incorporate these accesses in a standardized manner show the corresponding icon or icons next to their reference. - The price of the tables with WIRING ACCESS will be increased for each unit incorporated, according to the price indicated in the table below.. - To order other tables with access to wiring that do not have standardized outlets (they will not contain any icon), consult with the sales department. 	<p>Wiring access system with "Push Latch" opening system. Made of ABS. Incorporates "Anti-Dust" system that avoids dust accumulation in the wiring area..</p> <ul style="list-style-type: none"> - To request a table with higher access to wiring must be added: <ul style="list-style-type: none"> · Access wiring U: the letter U at the end of the requested reference. - The models that incorporate these accesses in a standardized manner show the corresponding icon or icons next to their reference. - The price of the tables with WIRING ACCESS will be increased for each unit incorporated, according to the price indicated in the table below.. - To order other tables with access to wiring that do not have standardized outlets (they will not contain any icon), consult with the sales department.

Surface / structure combinations

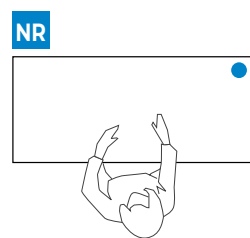
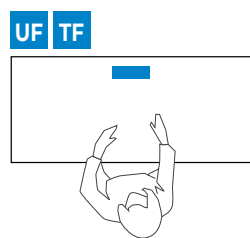
Surface / Structure combinations	WIRING ACCESS T U		
	White	Aluminized	Black
Surface: White Structure: Any finish			
Surface: Any finish (less white) Structure: White			
Surface: Any finish (less white) Structure: Black			

Superior cable access location to cabling and connections

Rectangular desks - 60, 67,69 and 80 cm wide

Front access

Right access



Packs, weights & volumes

Model	Packs	Weights	Volumes
Talent · Series 100	-	-	-
Talent · Series 300	-	-	-
Talent · Series 500	-	-	-

Ecodesign

	Talent · Series 100	Talent · Series 300	Talent · Series 500
Recycled materials	67,24%	69,87%	62,99%
Production	100%		
Transportation	100%		
Use	Easy		
Disposal	91,83%	97,89%	91,32%

Recycled materials: Maximum use of materials to eliminate waste and minimize residues. Use of recyclable materials and recycled materials in components that do not affect functionality and durability. **Production:** Maximum optimization of energy use. Minimum environmental impact. State-of-the-art technological systems. Zero wastewater discharge. VOC-free coatings. Processes free of heavy metals, phosphates, OC and COD. **Transport:** Dismountable systems. Volumes that facilitate space optimization. Maximum reduction of energy consumption for transport. **Use:** Quality and guarantee. Long useful life. Possibility of substitution and replacement of elements. **Disposal:** Waste reduction. Reuse system of supplier-manufacturer packaging. Easy separation of components. Solvent-free water-based printing inks on packaging.

Regulations & EPD

Talent has passed the tests carried out in our laboratory and the tests performed at the Instituto Tecnológico del Mueble (AIDIMA) corresponding to the standards:

Regulations	Description	
UNE - EN 527 - 1:2011	Office furniture. Work tables. Parte 1: Dimensions.	Talent 100
UNE - EN 527 - 2:2017 + A1:2019	Office furniture. Work tables. Parte 2: Safety, strength and durability requirements.	Talent 100
UNE-EN 15372:2017	Furniture. Strength, durability and safety. Requirements for non-domestic tables.	Talent 300 Talent 500
CERTIFICACIÓN GS.	Product complies with product safety law with respect to safety and health assurance.	Talent 300 Talent 500

Certificates

The different programs allow points to be obtained in different environmental categories, referring to sustainable plots, materials and resources, efficiency in water, energy and atmosphere, indoor environmental quality, and innovation and design, which are applied to a building in order to obtain LEED certification.



10