

# OWWI



ACTIU

# OWWI

by Arnau Reyna



# Sitting with **WOW** effect

OWWI is an icon recognisable to the touch and to the eye. Its design conveys simplicity, formal charge and versatility to define an armchair that stands out for its enveloping backrest. The characteristic wrinkles of its upholstery draw the Ws that give rise to its name and generate a welcoming sensation of embrace at every sitting position. Its high formal charge and its aesthetic warmth allow the sets formed by the armchairs and the two-seater sofas of the OWWI series to endow any space with sophistication.

OWWI es un icono reconocible al tacto y a la vista. Su diseño transmite sencillez, carga formal y versatilidad para definir un sillón que destaca por su envolvente respaldo. Las características arrugas de su tapicería dibujan las W que dan origen a su nombre y generan una acogedora sensación de abrazo en cada postura sentada. Su alta carga formal y su calidez estética permiten que los conjuntos formados por las butacas y los sofás de dos plazas de la serie OWWI doten de sofisticación cualquier espacio.

# by ARNAU REYNA

“We want to create  
future design icons”



A+R designs products that connect with the user and the spaces they inhabit. A+R starts with simple ideas that evolve throughout the design process. Timeless pieces that are not influenced by passing trends. A+R believes in design as a strategy, an intangible tool that is a fundamental pillar for companies as an engine of productivity and growth. “Design is not just having a good idea, but a criterion with which to draw the business roadmap”.

A+R diseña productos que conectan con el usuario y los espacios que habita. A+R parte de ideas sencillas que evolucionan a lo largo del proceso de diseño. Piezas atemporales que no se dejan influir por tendencias pasajeras. A+R cree en el diseño como estrategia, una herramienta intangible que es un pilar fundamental para las empresas como motor de productividad y crecimiento. “El diseño no es sólo tener una buena idea, sino un criterio con el que trazar la hoja de ruta empresarial.”

A+R conçoit des produits qui s'associent à l'utilisateur et aux espaces qu'il habite. A+R part d'idées simples qui évoluent tout au long du processus de conception. Des pièces intemporelles qui ne sont pas influencées par des tendances passagères. A+R considère le design comme une stratégie, un outil intangible qui constitue un pilier fondamental pour les entreprises en tant que moteur de productivité et de croissance. “Le design n'est pas seulement une bonne idée, c'est un critère qui permet de tracer la feuille de route de l'entreprise.”

A+R entwirft Produkte, die sich mit dem Benutzer und den von ihm bewohnten Räumen verbinden. A+R beginnt mit einfachen Ideen, die sich im Laufe des Designprozesses weiterentwickeln. Zeitlose Stücke, die nicht von vorübergehenden Trends beeinflusst werden. A+R glaubt an Design als Strategie, ein immaterielles Werkzeug, das ein grundlegender Pfeiler für Unternehmen als Motor für Produktivität und Wachstum ist. “Design ist nicht nur eine gute Idee, sondern ein Kriterium, mit dem man den Fahrplan für das Unternehmen erstellen kann”.





WOW







Investing in new hybrid spaces that enhance both the physical and emotional wellbeing of people is essential to create environments in which to connect with our loved ones... or simply disconnect.

Invertir por nuevos espacios híbridos en los que potenciar tanto el bienestar físico como emocional de las personas resulta fundamental para crear ambientes en los que conectar con los nuestros... o sencillamente desconectar.

Il est essentiel d'investir dans de nouveaux espaces hybrides qui améliorent le bien-être physique et émotionnel des personnes afin de créer des environnements dans lesquels nous pouvons nous connecter avec nos proches... ou simplement nous déconnecter.

Investitionen in neue hybride Räume, die sowohl das physische als auch das emotionale Wohlbefinden der Menschen fördern, sind unerlässlich, um Umgebungen zu schaffen, in denen wir mit unseren Lieben in Kontakt treten können... oder einfach nur abschalten können.















## TECHNICAL FEATURES

### Información técnica

El tapizado exterior con sus arrugas, da como resultado la W que conforma su nombre, generando una pieza de gran calidad y sofisticación, que combinado con su estructura que abraza la pieza le aporta el equilibrio perfecto.

The exterior upholstery with its wrinkles, results in the W that forms its name, generating a piece of great quality and sophistication, which combined with its structure that embraces the piece gives it the perfect balance.

Le revêtement extérieur, avec ses plis, donne le W qui forme son nom, générant une pièce de grande qualité et de sophistication, qui, combinée à sa structure qui englobe la pièce, lui donne l'équilibre parfait.

Die äußere Polsterung mit ihren Falten, gibt als Ergebnis das W, das seinen Namen bildet, wodurch ein Stück von großer Qualität und Raffinesse, die mit seiner Struktur, die das Stück umarmt, gibt es die perfekte Balance.



### EIDOS TABLES / MESAS

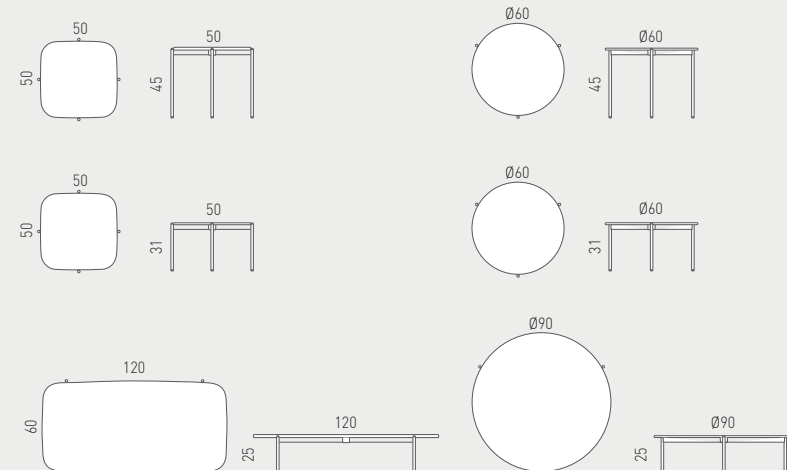

## ACTIU TECHNOLOGY PARK



### DESIGN & ARCHITECTURE

Space management and design  
Products. Own patents  
Communication

### SUSTAINABILITY

Sustainable production  
Product. Eco-design  
Services, efficient logistics system  
Actiu Technology Park, certified LEED® Platinum & WELL Platinum

### MANUFACTURER

We are manufacturers  
Domain raw materials and processes  
Technology and Innovation  
Standardized and specific solutions

### GLOBAL COVERAGE

Presence in more than 90 countries  
Global equipment solutions. Corporate, Health, Education, Contract, Transport.



ACTIU, National Design Award 2017  
ACTIU, Premio Nacional de Diseño 2017

### ACTIU: 50 YEARS DESIGNING PUBLIC SPACES AND WORKSPACES.

Actiu is an industrial company working within the installation sector and specialising in the manufacture of furniture. Actiu's flexibility and productive capacity enable the company to carry out comprehensive equipment projects worldwide, providing solutions that favour the wellbeing of people.

### ACTIU, 50 AÑOS DISEÑANDO ESPACIOS PÚBLICOS Y DE TRABAJO.

Actiu es una empresa con una trayectoria industrial en el sector de la instalación, especializada en la creación de mobiliario, cuya flexibilidad y capacidad productiva permite desarrollar proyectos de equipamiento global a nivel internacional aportando soluciones que ofrezcan el bienestar de las personas.

### ACTIU, 50 ANS DE CONCEPTION D'ESPACES PUBLICS ET DE TRAVAIL.

Actiu est une entreprise dotée d'un parcours à caractère industriel dans le secteur de l'installation, qui se spécialise dans la création de mobilier, et dont la flexibilité et la capacité de production permettent de développer des projets d'équipement global à un niveau international, tout en apportant des solutions qui puissent offrir du bien-être aux personnes.

### ACTIU, 50 JAHRE DESIGN UND PRODUKTION VON MÖBELN FÜR ÖFFENTLICHE EINRICHTUNGEN UND ARBEITSRÄUME.

Unsere ständige Forschung, Weiterentwicklung, Flexibilität und Erfahrung ermöglichen es uns, Projekte im privaten und öffentlichen Bereich der verschiedensten Sektoren auf nationaler und internationaler Ebene durchzuführen. Stillstand ist uns fremd. Uns treibt das Bedürfnis an, näher an den Menschen zu sein und Lösungsmöglichkeiten zu entwickeln, die den Endnutzern Wohlgefühl bieten.

### CERTIFICATES AND REFERENCES

ACTIU products fulfill all demands about management, quality and sustainability to provide extra value to the projects using recycled materials to get the recyclable final product.



Actiu, the first industrial company in the world to obtain the WELL v2 and LEED Platinum Certification



ACTIU reserves the right to carry out technical, dimensional and finishing modifications that it considers appropriate with respect to the information detailed in this document, so please check before confirming your orders.

ACTIU se reserva el derecho de llevar a cabo las modificaciones técnicas, dimensionales y de acabados que estime conveniente respecto a la información detallada en este documento, por el que se ruega verificación antes de confirmar sus pedidos.

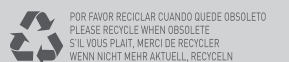



[www.actiu.com](http://www.actiu.com)