

DORIK

by ODOS
Design



Office
& contract
tables

ACTIU

Iconic and Multipurpose *Icónica y* Polivalente

Dorik is the table collection inspired by the grandeur of the classical Doric columns of Greek culture. As in classical Greek architecture, this collection of tables is characterized by timeless elegance and a simple yet clean look with harmonious proportions.

Dorik es la colección de mesas inspirada en la grandeza de las columnas clásicas dóricas de la cultura griega. Como en la arquitectura de la Grecia clásica, esta colección de mesas se caracteriza por su elegancia atemporal y su aspecto sencillo pero limpio de proporciones armónicas.



“For over 21 years, Odosdesign has accumulated expertise being creative, researching and transforming design to deliver the most impactful and lasting results. Their work is solution-driven and committed to the goal of cultivating a long-term relationship with clients, shaping the industry by using creativity as a strong advantage to shape business and design culture.”

“Durante más de 21 años, Odosdesign ha acumulado experiencia utilizando la creatividad, la investigación y el diseño transformador para ofrecer los resultados más impactantes y duraderos. Su trabajo es una solución y un compromiso con el objetivo de cultivar una relación a largo plazo con los clientes, dando forma a la industria mediante el uso de la creatividad como una fuerte ventaja para dar forma a las empresas y la cultura del diseño.”



DORIK

by ODOS
Design













A further return to
elegance *and structural
stability*

Una vuelta más a la
elegancia *y estabilidad
estructural*

Each table is meticulously crafted with exceptional attention to detail, showcasing the mastery of rotational molding.

Cada mesa está meticulosamente fabricada con una atención excepcional al detalle, exhibiendo la maestría del moldeo rotacional.













Growing in
every way

Creceamos en todos
los sentidos







Variety is the spice of life En la *variedad* está el gusto

Dorik offers a wide range of sizes, heights and features to suit various needs. It can also be expanded with several columns, facilitating the configuration of meeting tables.

Dorik ofrece una amplia gama de tamaños, alturas y prestaciones para adaptarse a diversas necesidades. Permite además su expansión con con varias columnas, facilitando la configuración de mesas de reunión.











Design *without borders*.
A table that adapts to
everything, whether
indoors or outdoors.

Diseño *sin fronteras*.
Una mesa que se
adapta a todo, ya
sea *interior o exterior*.

Dorik features phenolic surfaces, specially designed to increase their durability and resistance to weather conditions. This makes them ideal for use in outdoor environments and contract spaces, such as restaurants, cafeterias and other high-demand spaces.

Dorik cuenta con superficies fenólicas, especialmente diseñadas para aumentar su durabilidad y resistencia a condiciones climáticas. Esto las hace ideales para su uso en entornos exteriores y espacios contract, como restaurantes, cafeterías y otros espacios de alta demanda.











A table to enjoy
your outside world.

Una mesa para
disfrutar de
tu mundo exterior.













DORIK

SURFACES / SUPERFICIES

PHENOLICS / FENÓLICOS

10 mm

Black core
Núcleo negro

Coloured core
Núcleo coloreado

WHITE TRAFIC
BLANCO TRAFIC

OLIMPO MARBLE
MARMOL OLIMPO

PULPIS LIGHT
PULPIS LIGHT

SAMAS BLACK
SAMAS NEGRO

DEKTON® by Cosentino Ultra-compact Engineered Stone Surfaces
Superficies de piedra técnica ultracompacta

12 mm

REM WHITE
REM BLANCO

KEYLA BLACK
KEYLA NEGRO

COLUMN / COLUMNA

POLYETHYLENE / POLIETILENO

Made with an average thickness of 6 mm / Fabricada con un espesor medio de 6 mm

WHITE
BLANCA

VISON
VISÓN

BLACK
NEGRA

MELAMINE / MELAMINA

19 mm

WHITE
BLANCO

COCO GREY
GRIS COCO

ACACIA
ACACIA

OAK
ROBLE

CHESTNUT
CASTAÑO

FRESNO
FRESNO

BLACK ANTI-FINGERPRINT
NEGRO ANTIHUELLA

DM

19 mm

ROBLE
OAK

MEASUREMENTS / MEDIDAS

Meeting tables - catering - Height 74 cm / Mesas reunión - restauración - Altura 74 cm

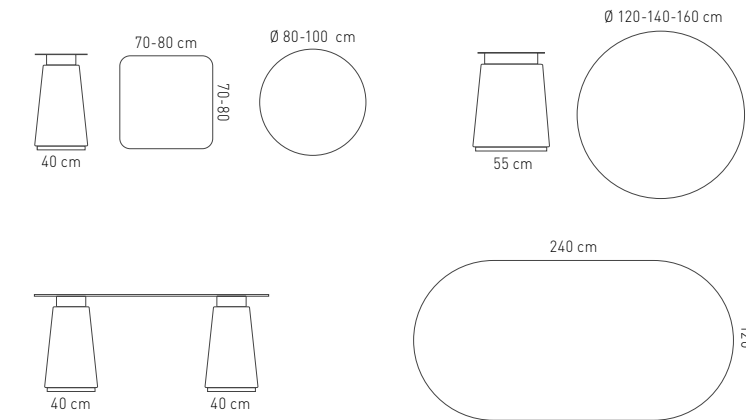

Coffee tables - Height 35 cm / Mesas centro - Altura 35 cm

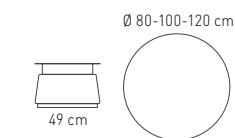

Contract tables - Height 105 cm / Mesas contract - Altura 105 cm

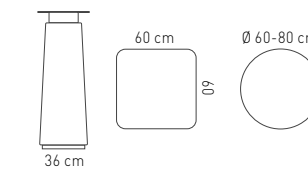

WIRING AND CONNECTIONS / CABLEADO Y CONEXIONES

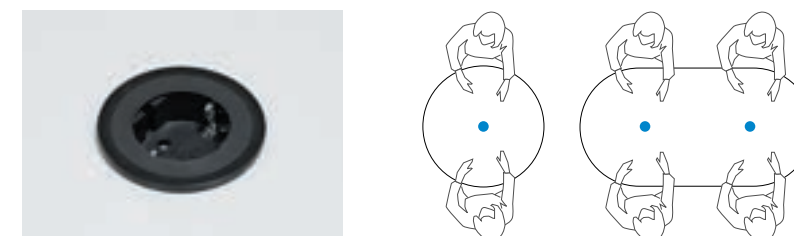



ACTIU TECHNOLOGY PARK

DESIGN & ARCHITECTURE

Space management and design
Products. Own patents
Communication

SUSTAINABILITY

Sustainable production
Product. Eco-design
Services, efficient logistics system
Actiu Technology Park, certified LEED®
Platinum

MANUFACTURER

We are manufacturers
Domain raw materials and processes
Technology and Innovation
Standardized and specific solutions

GLOBAL COVERAGE

Presence in more than 90 countries
Global equipment solutions. Corporate, Health,
Education, Contract, Transport.

CERTIFICATES AND REFERENCES

ACTIU products fulfill all demands about management, quality and sustainability to provide extra value to the projects using recycled materials to get the recyclable final product.



Actiu, the first industrial company
in the world to obtain the
WELL v2 and LEED Platinum Certification



ACTIU: 50 YEARS DESIGNING PUBLIC SPACES AND WORKSPACES.

Actiu is an industrial company working within the installation sector and specialising in the manufacture of furniture. Actiu's flexibility and productive capacity enable the company to carry out comprehensive equipment projects worldwide, providing solutions that favour the wellbeing of people.

ACTIU, 50 AÑOS DISEÑANDO ESPACIOS PÚBLICOS Y DE TRABAJO.

Actiu es una empresa con una trayectoria industrial en el sector de la instalación, especializada en la creación de mobiliario, cuya flexibilidad y capacidad productiva permite desarrollar proyectos de equipamiento global a nivel internacional aportando soluciones que ofrezcan el bienestar de las personas.

ACTIU, 50 ANS DE CONCEPTION D'ESPACES PUBLICS ET DE TRAVAIL.

Actiu est une entreprise dotée d'un parcours à caractère industriel dans le secteur de l'installation, qui se spécialise dans la création de mobilier, et dont la flexibilité et la capacité de production permettent de développer des projets d'équipement global à un niveau international, tout en apportant des solutions qui puissent offrir du bien-être aux personnes.

ACTIU, 50 JAHRE DESIGN UND PRODUKTION VON MÖBELN FÜR ÖFFENTLICHE EINRICHTUNGEN UND ARBEITSRÄUME.

Unsere ständige Forschung, Weiterentwicklung, Flexibilität und Erfahrung ermöglichen es uns, Projekte im privaten und öffentlichen Bereich der verschiedensten Sektoren auf nationaler und internationaler Ebene durchzuführen. Stillstand ist uns fremd. Uns treibt das Bedürfnis an, näher an den Menschen zu sein und Lösungsmöglichkeiten zu entwickeln, die den Endnutzern Wohlgefühl bieten.

ACTIU reserves the right to carry out technical, dimensional and finishing modifications that it considers appropriate with respect to the information detailed in this document, so please check before confirming your orders.

ACTIU se reserva el derecho de llevar a cabo las modificaciones técnicas, dimensionales y de acabados que estime conveniente respecto a la información detallada en este documento, por el que se ruega verificación antes de confirmar sus pedidos.

We dream to go beyond our own immediate reality. We design to mature our desires. We walk because only our initiative changes the world and breaks new ground. We move ourselves by being ourselves without the fear of underperforming against our own expectations and goals.

D. Vicente Berbegal Pérez

President and Founder of the Actiu Group.



ACTIU, National Design Award 2017
ACTIU, Premio Nacional de Diseño 2017

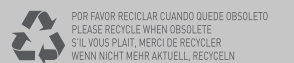



www.actiu.com